



PRESSURE MEASUREMENT
Mining Gauge - Staple Lock SL
 Type R3: Stainless steel case with brass internals

Data Sheet P MIN SL3

Service Intended

For mining equipment and plants where hydraulic support is required.

Case Details

Nominal Dia: 50, 63mm diameter.
 Material: Stainless steel 304

Bezel

S/Steel rolled ring type - tamper proof.
 Material: Stainless steel 304.

Pressure Connections

Configuration: Bottom connection.
 Material: Brass, staple lock design. (S/steel on request)

Pressure Element

Material: Type 3: Cu-alloy.

Pressure Range

0... 60MPa (also bar, psi, etc.)

Geared Movement

Material: Clockwork brass.

Pointer

Collet: Aluminium or brass Blade: Black aluminium

Dial

Material: Aluminium, white with black lettering.

Window

Plexiglass

Weather Protection

IP 65 Dust & weather proof.

Working Pressure

Steady: Full scale value
 Fluctuating: 90% of full scale value
 Short Period: 130% of full scale value

Accuracy Class

Class 1.6

Operating Temperature

Ambient: -20 °C to + 60 °C
 Medium: +70 °C (soldered tube): + 100 °C (brazed / tig welded tube)

Optional Extras

Calibration Certificate
 Customized scale plates (customer logo, red line, etc)
 Special Dials, other than standard (dual scale, bar, psi)
 Damped movement (Vibragaugae)
 Colour Coding of dial

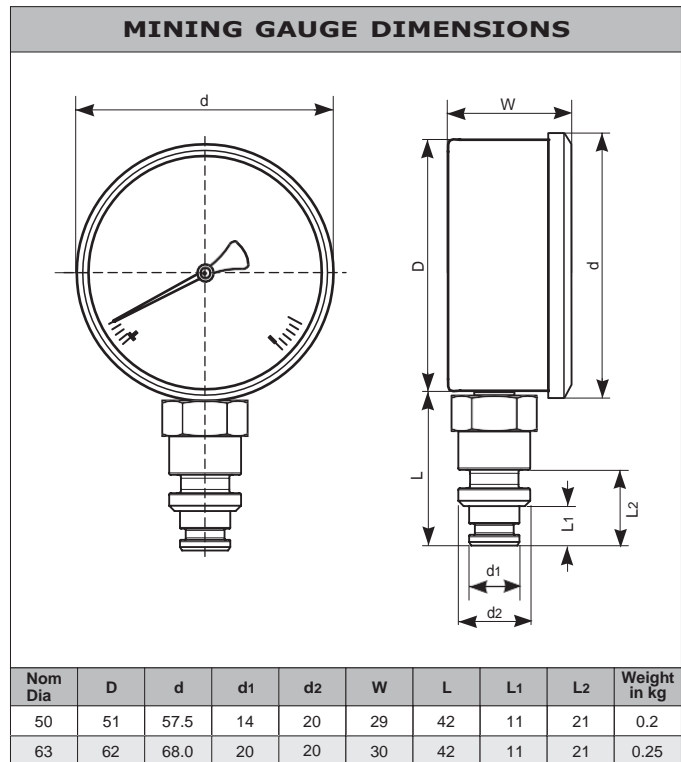

HOW TO ORDER USING OUR PART NUMBERS

Casing Type: _____ R 3 A 50 / 63 G SL 25 MPa
 Gauge Type: _____
 Configuration: _____
 Dial Size: _____
 Glycerine filled: _____
 Connection Size: _____
 Pressure Range: _____